

UNI-T[®]

Instruments.uni-trend.com

UPO6000LP Series High-Resolution

Oscilloscopes

Data Sheet



V1.0

May 2026

Product Introduction

The UPO6000LP series high-resolution oscilloscopes provide a maximum bandwidth of 1 GHz and a maximum sampling rate of 5 GSa/s. The series is available with 4 or 8 analog channels, and includes one external trigger input (EXT) and one signal generator output. The maximum memory depth is up to 500 Mpts/CH.

The oscilloscopes incorporate proprietary Ultra Phosphor 3.0 technology, achieving a waveform capture rate of up to 1,000,000 waveforms/s. The advanced digital trigger system offers high trigger sensitivity and low trigger jitters, and supports a comprehensive range of triggering functions, including advanced triggers as well as serial bus triggering and decoding.

In addition, the UPO6000LP series supports a wide range of acquisition and analysis functions, including spectrum analysis, power analysis, three-phase power analysis, histogram analysis, waveform recording, Enhanced Resolution (ERES), hardware-accelerated mask testing, and search & navigate. The instruments also provide extensive measurement and mathematical processing functions.

Brand New Appearance Design

The instrument features a compact, rack-mountable design with a slim form factor. With a height of 1U, it is ideal for multi-instrument system integration, high-density rack installations, and remote system control applications. The system supports synchronous triggering across multiple instruments and can be expanded to accommodate up to 128 oscilloscopes.

Each unit integrates 4 or 8 analog input channels, one external trigger input (EXT), and one built-in function/arbitrary waveform generator output. The instrument is equipped with footpads, and its flat enclosure design facilitates easy stacking and placement. When used with an external touch display, the multi-instrument integration solution includes a rack-mount kit for seamless rack installation.

UPO6104LP

214mm



UPO6108LP

339mm



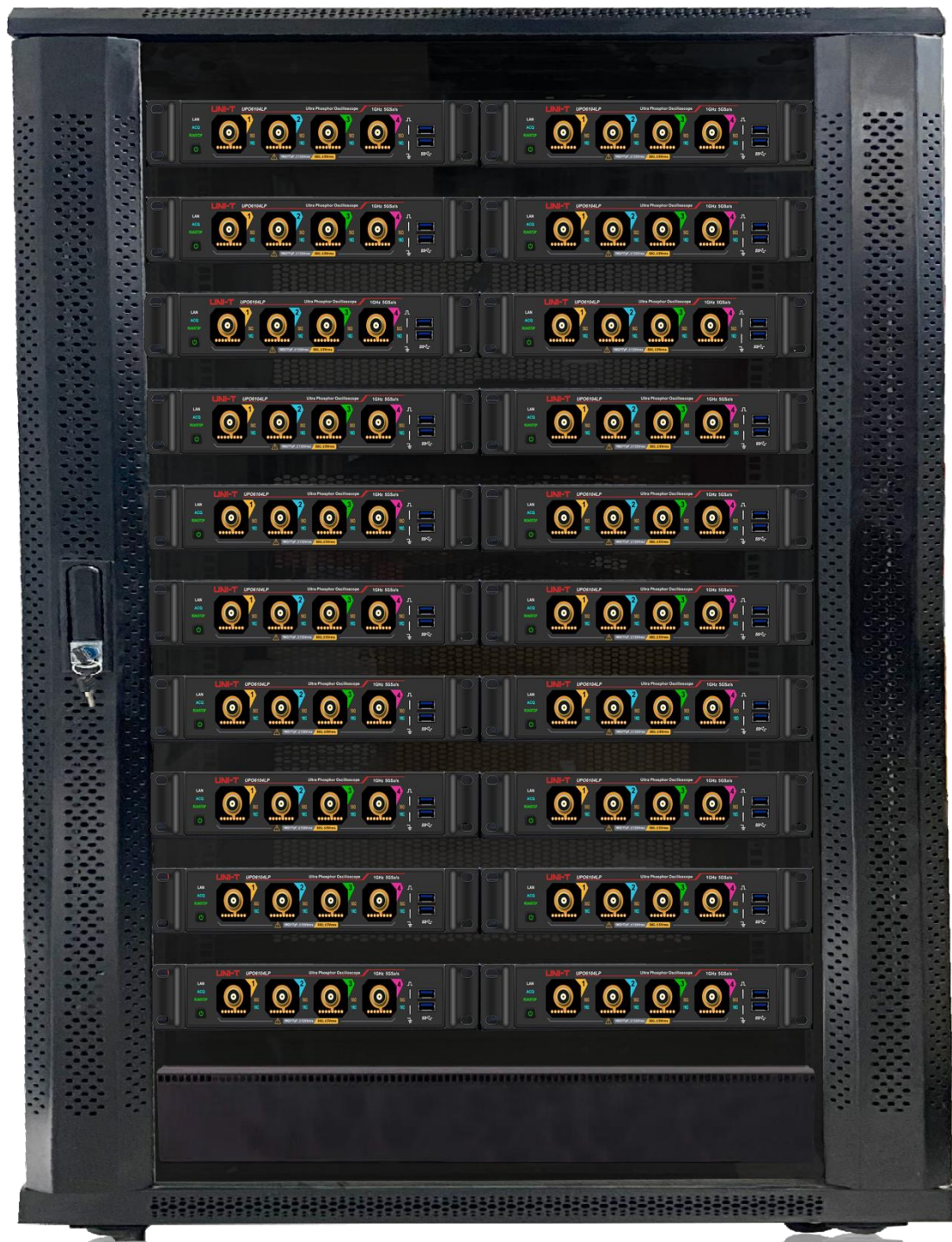

Features and Advantages

- Analog channel bandwidth: 1 GHz/500 MHz/350 MHz
- Real-time sampling rate of the analog channel: 5 GSa/s
- 12-bit vertical resolution, with up to 4096 points, ensures that the waveform details are clearly visible.
- 4/8 analog channels+EXT+Gen, maximum memory depth up to 500 Mpts/CH
- Maximum waveform capture rate: 500,000 wfms/s (sequence mode: 1,000,000 wfms/s)
- All-in-one comprehensive measurement solution that includes a digital oscilloscope, function/arbitrary waveform generator, spectrum analyzer, digital voltmeter, frequency counter, protocol analyzer, Bode plot, and power analyzer.
- Built-in 50 MHz function / arbitrary waveform generator supports real-time loading of oscilloscope screen data to the generator's arbitrary waveform output, with multiple built-in arbitrary waveforms (optional for 4-channel models only).
- Supports Bode plot loop test analysis for system stability.
- 12 serial protocol analysis: RS232/422/485/UART, I²C, SPI, CAN, CAN-FD, LIN, FlexRay, SENT, MIL-STD-1553, ARINC 429, AudioBus (I2S\LJ\RJ\TDM), and Manchester.
- Hardware-based real-time, uninterrupted waveform recording and analysis of up to 400,000 frames, with support for export to USB storage devices.
- Enhanced FFT analysis up to 5M points, with spectrum analyzer functions including frequency setup, waterfall curve, detection settings, and markers.
- Supports ERES (enhanced resolution) of up to 4-bit
- 56 kinds of parameter measurements
- Multi-channel 7-digit hardware frequency counter supports frequency refresh time and adjustable effective digit settings.
- DVM multi-channel RMS measurement: DC, AC RMS, and DC+ACRMS
- Multiple trigger types: Edge, pulse width, video, ramp, runt pulse, window, delay, timeout, duration, setup & hold, Nth edge, and pattern triggering.
- Zone trigger for capturing sporadic signals and observing complicated signals.
- Ultra Phosphor 3.0 provides a super fluorescent display effect with up to 256 levels of gray.
- Multiple peripheral interfaces: USB Host & Device, LAN, HDMI, 10 MHz Ref In/Out, EXT Trig, AUX Out (Trig Out, Pass/Fail, DVM)
- Supports SCPI (Standard Command for Programmable Instruments)
- Supports on-line update

Low Trigger Delay, Multi-Machine Synchronization Solution

In the rack-mounted multi-level synchronization solution, the UPO6000LP is equipped with a clock synchronization interface, auxiliary output interface, and an external trigger channel. Supported by a Gigabit Ethernet interface, the SCPI response speed is optimized to enhance the stability and transmission efficiency of the data link. A 10 Gbps optical port is available as an option.

For users requiring multi-channel integrated solutions, UNI-T offers a synchronous chassis solution that supports up to 64 channels in a single chassis, with expandability to a maximum of 512 channels.

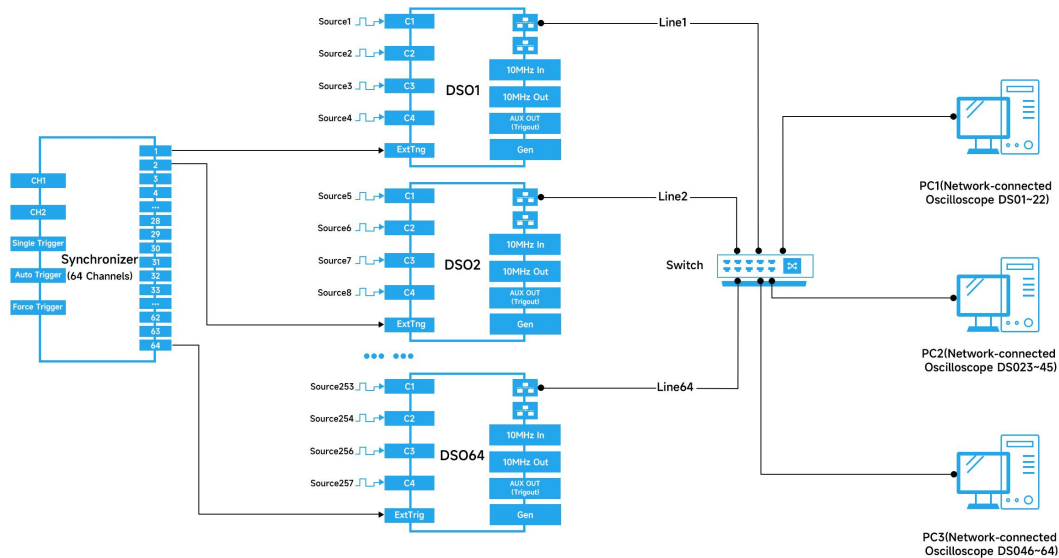

Design Features

High-resolution

12-bit high-resolution ADC sampling has a quantization level of up to 4096, which is 16 times that of a traditional 8-bit ADC, allowing for better restoration of waveform details.

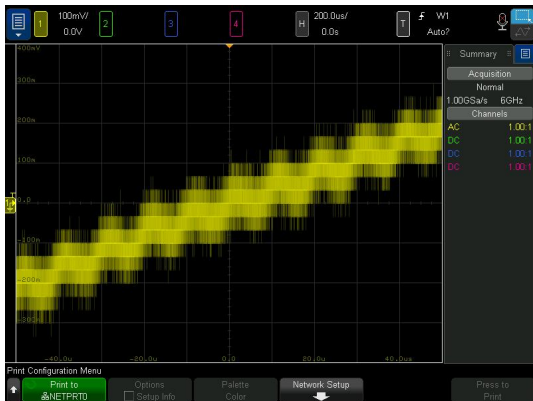

8-bit



12-bit



The excellent background noise, which is only 75 μ Vrms at the full bandwidth of 1 GHz, allows the 12-bit ADC to perform optimally.

Application Scope



All-in-one Comprehensive Measurement

The UPO6000LP series high-resolution oscilloscope integrates multiple independent instruments into one unit, including a digital oscilloscope, function/arbitrary waveform generator, spectrum analyzer, digital voltmeter, high-precision frequency counter, protocol analyzer, Bode plot analyzer, and power analyzer. This offers users the most flexible and cost-effective solution to meet their specific needs.

Digital Oscilloscope

- Bandwidth: 1 GHz/500 MHz/350 MHz
- Maximum real-time sampling rate: 5 GSa/s
- Maximum memory depth: 500 Mpts/CH
- 4/8 analog channels, 1 external trigger channel

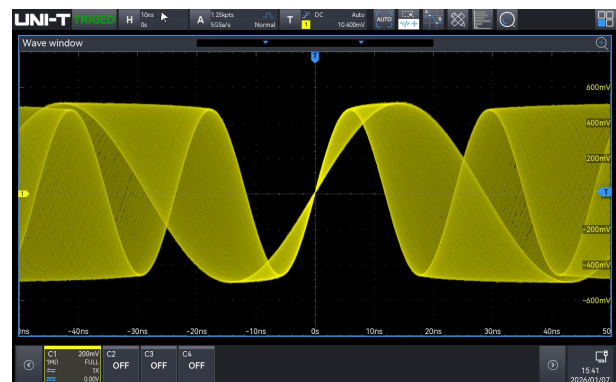

Function/Arbitrary Waveform Generator (optional for 4-channel models only)

- Maximum frequency: 50 MHz, sample rate 312.5 MSa/s
- Vertical resolution: 16-bit
- Multiple built-in standard waves: Sine, square, pulse, ramp, arbitrary, noise, and DC

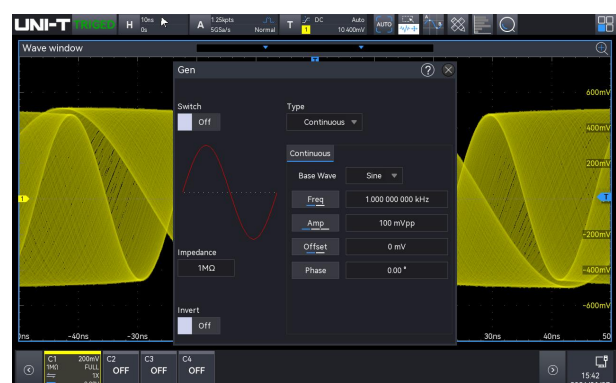

- Supports AM, FM, ASK, FSK, and sweep frequency output

Spectrum Analyzer

- Standard enhanced FFT, up to 5 Mpts x 4-channel signal analysis
- Waterfall curve
- 4 trace types + 4 detection modes
- Mark type: Auto, manual, and threshold
- Marker list display

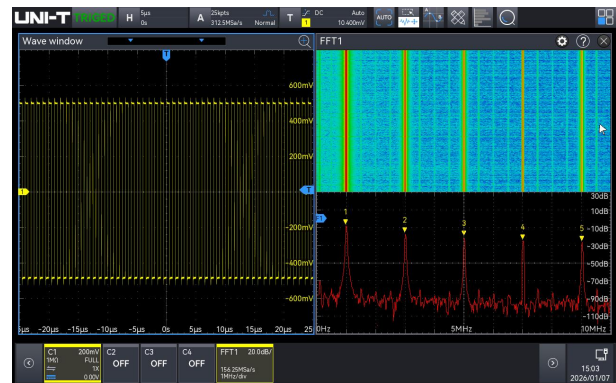

Digital Voltmeter

- 4-digit voltmeter
- Measurement: DC, AC RMS, and AC+DCRMS
- Limit alarm

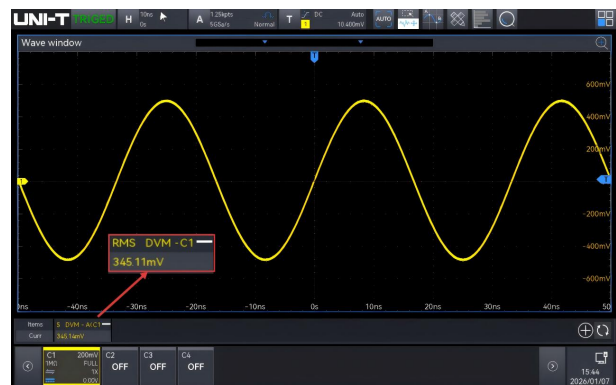

High-precision Frequency Counter

- 7-digit hardware frequency counter
- Frequency counter refresh time and effective digital adjustment
- Totalize counter

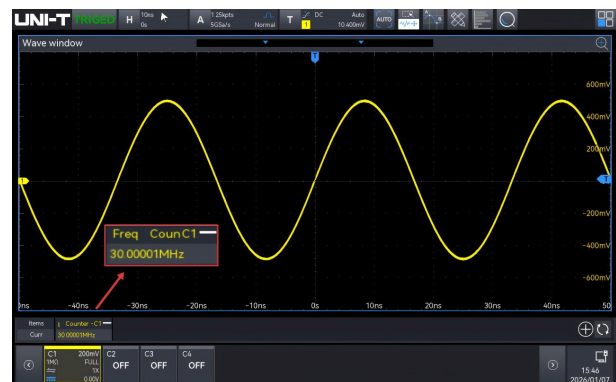

Bode Plot Analyzer (optional for 4-channel models only)

- Built-in function/arbitrary waveform generator
- Frequency response analysis
- Loop stability analysis
- Filter analysis
- Amplifier analysis



Protocol Analyzer

- 12 types of protocol triggering and decoding, covering most applications, including computers, embedded, automotive, avionics, and audio fields
- Supports decoding in pause, record, and other operating states
- Supports event list display and search functions



Option Name	Description	Option Model	Standard/Option
Computer serial bus triggering and analysis	RS232/422/485/UART	-	Standard
Embedded serial bus triggering and analysis	I ² C, SPI	-	Standard
Automobile serial bus triggering and analysis	CAN	UPO6000LP-CAN	Option
Automobile serial bus triggering and analysis	LIN	UPO6000LP-LIN	Option
Automobile serial bus triggering and analysis	CAN-FD	UPO6000LP-CAN-FD	Option
Automobile serial bus triggering and analysis	FlexRay	UPO6000LP-FLEX	Option
Automobile sensor bus triggering and analysis	SENT	UPO6000LP-SENT	Option
Audio serial bus triggering and analysis	Audio	UPO6000LP-AUDIO	Option
Aerospace serial bus triggering and analysis	MIL-STD-1553	UPO6000LP-MIL1553	Option
Aerospace serial bus triggering and	ARINC 429	UPO6000LP-ARINC429	Option

analysis			
Wireless communication trigger and analysis	Manchester	UPO6000LP-MANCH	Option

Power Analyzer (Option)

With the development of chip technology, the requirements for power supply systems are also increased. Nowadays, low-voltage, high-current power supply networks have become a trend. Especially for chips or networks composed of precision components, it is essential to ensure reliable power supply and noise suppression across various parts of the circuit, as well as to maintain the integrity of signal transmission between chips. This presents greater challenges for power supply testing. Designers are now more focused on energy-efficient power supplies and response speed to ensure the power supply remains stable and clean. Based on this, power integrity testing becomes particularly important. Power integrity directly affects signal integrity, and conversely, signal quality also reflects power quality. Furthermore, power quality can cause a series of electromagnetic interference issues, which can be a significant concern for designers. Therefore, having an oscilloscope capable of power analysis is undoubtedly your best choice.

UPO6000LP series provides a comprehensive set of power analysis tools and evaluation results. To use them, simply select the appropriate analysis type and connect the voltage probe and current probe to the power system test point or specified test fixtures, as shown in the diagram. Then, connect to the desired channel for observation and make any necessary fine-tuning adjustments to achieve your desired results

- Power Quality
- Harmonic Analysis
- Switching Loss
- Transient response
- Surge Current
- Rds(on)
- Slew Rate
- Power efficiency
- Safe Operating Area
- Modulation Analysis
- Ripple Analysis
- Turn on/off time



“*” indicates features being added. Power analysis support is subject to the latest firmware available on the official website.

Timing Analyzer

Intelligent products such as mobile phones, smart wearables, home appliances, multimedia audio-video equipment, and automobile electronic accessories have strict requirements for the consistency of internal bus communication timing. UPO6000LP timing analysis function can analyze parameters like pulse width, amplitude, edge, setup time, and hold time for signals for I²C, SPI, CAN, and I2S. Additionally, it supports exporting conformance test reports.



Three-Phase Power Analysis

With the continuous development of modern power systems, the stability and reliability of three-phase power systems are essential to ensuring power supply quality. The three-phase power analysis software, by deeply integrating hardware innovations and intelligent algorithms, provides high-precision and high-efficiency testing capabilities. It supports synchronous sampling of three-phase voltage and current waveforms and integrates one-click key parameter measurement functions, including power quality, harmonic analysis, ripple analysis, efficiency, and DQ0 analysis. Paired with a real-time space vector diagram display, it accelerates the debugging of motor drive systems.

This solution delivers fast, accurate, and repeatable electrical measurement results in applications such as electric vehicle drive systems, industrial motor power quality evaluation, and renewable energy inverter testing. It serves as a highly efficient test tool for R&D validation and fault diagnosis in power systems, industrial automation, new energy, and other fields.

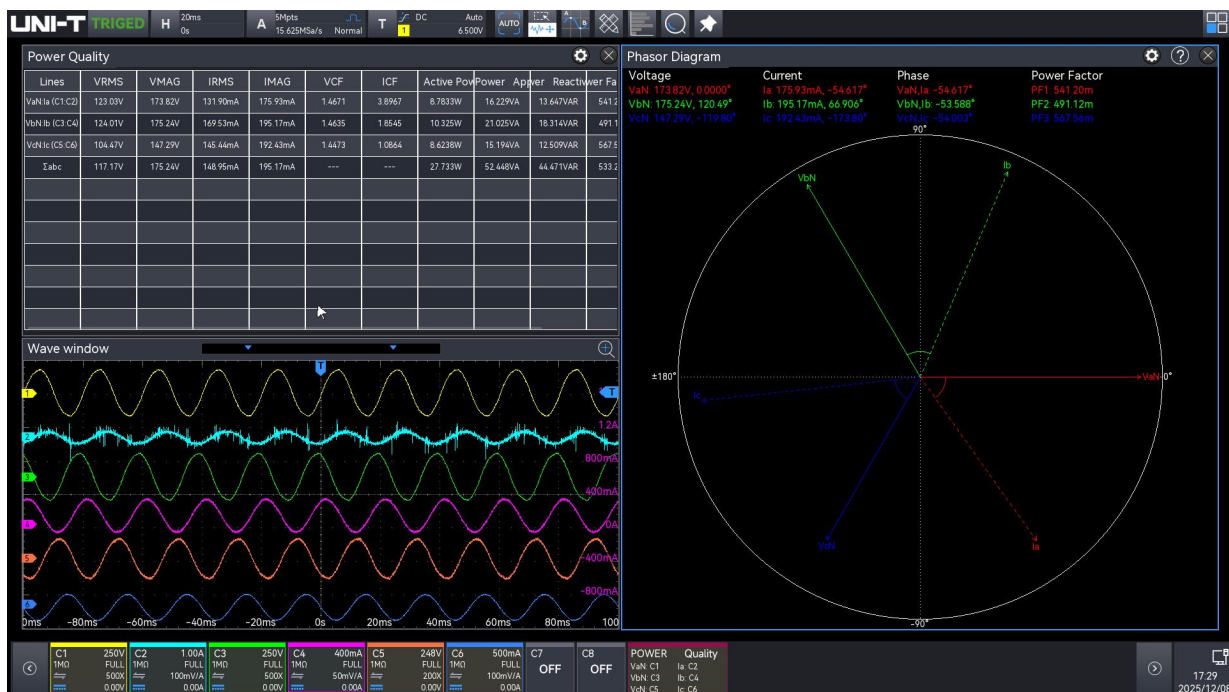

Ultra Phosphor 3.0

Using UNI-T's proprietary Ultra Phosphor 3.0 technology, which integrates multi-bank interleaved mapping and a segmented collaborative matrix processing architecture, the waveform capture rate is increased to 500,000 wfms/s, with up to 1,000,000 wfms/s in sequence mode.

Combined with information entropy-based intelligent detection for abnormal signals, this technology effectively handles occasional or intermittent probabilistic events encountered by engineers during testing, enabling seamless acquisition of abnormal signals.

Upgraded with the new Ultra Phosphor 3.0 super phosphor display technology, it supports 8-channel parallel graphics mapping with a processing rate of 20 Gbps, ensuring that even the most elusive signals are fully visible.

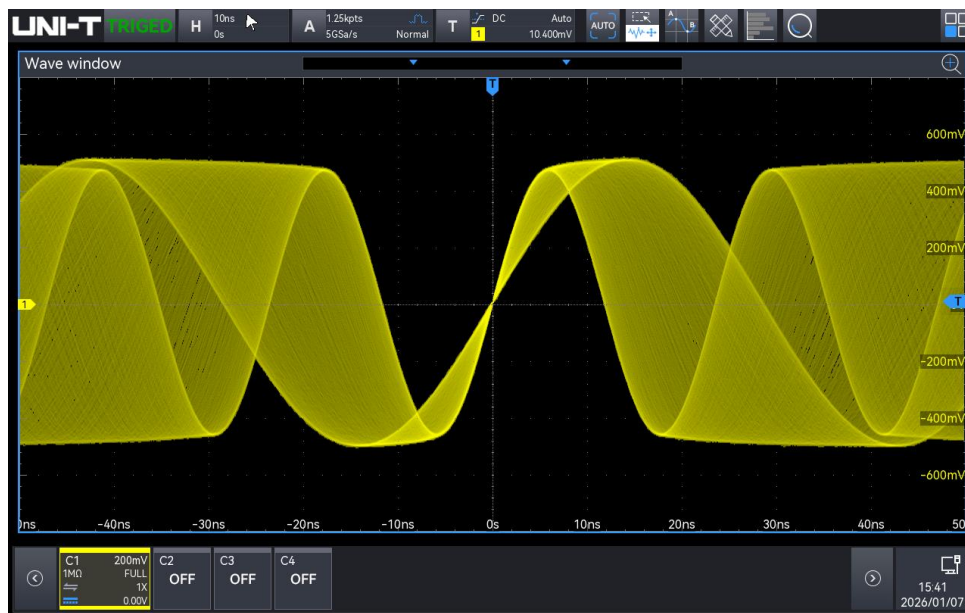

New Fast Autoselect Strategy

Fuzzy control is an intelligent control method based on fuzzy set theory, fuzzy linguistic variables, and fuzzy logic reasoning. This algorithm offers the advantages of fewer iterations, high speed, and strong anti-interference capability.

In conventional oscilloscopes, Autoselect is used to find the appropriate signal amplitude and frequency for display. However, significant differences in response speed often exist among oscilloscope vendors due to different implementation schemes, which can degrade the user experience.

UNI-T has redefined the Autoselect function by adopting a fast fuzzy algorithm based on analog signals, combined with multi-channel parallel processing technology and a high-precision 7-bit hardware frequency counter. This enables the oscilloscope to quickly determine, process, and display the amplitude and frequency of unknown signals during Autoselect.

The execution time is within 14 seconds for all channels enabled (8-channel models) and within 1 second for a single channel. This greatly enhances work efficiency and reduces the risk of user error, particularly for users who frequently change test objects or require high-speed testing.

Comprehensive Parameter Measurements

Parameter measurement is critical for engineers using oscilloscopes. The UPO6000LP series supports the display of up to 56 measurement parameters, with 27 parameters able to be displayed simultaneously. Measurement statistics show 9 parameters per page. Each parameter supports statistical displays of measured values, histograms, and trend plots. The histogram intuitively shows the probability distribution of the parameter, while the trend plot reflects its variation over time. The parameter snapshot function displays 39 measurement items for a single channel, including voltage-related and time-related parameters, with results continuously updated during operation. The UPO6000LP series also introduces new functions, including amplitude calculation strategy, top value strategy, and base value strategy, making parameter measurements more flexible for engineers. Additionally, a burst setup function has been added to display burst-related parameters, providing timely and accurate insights into channel measurement data.

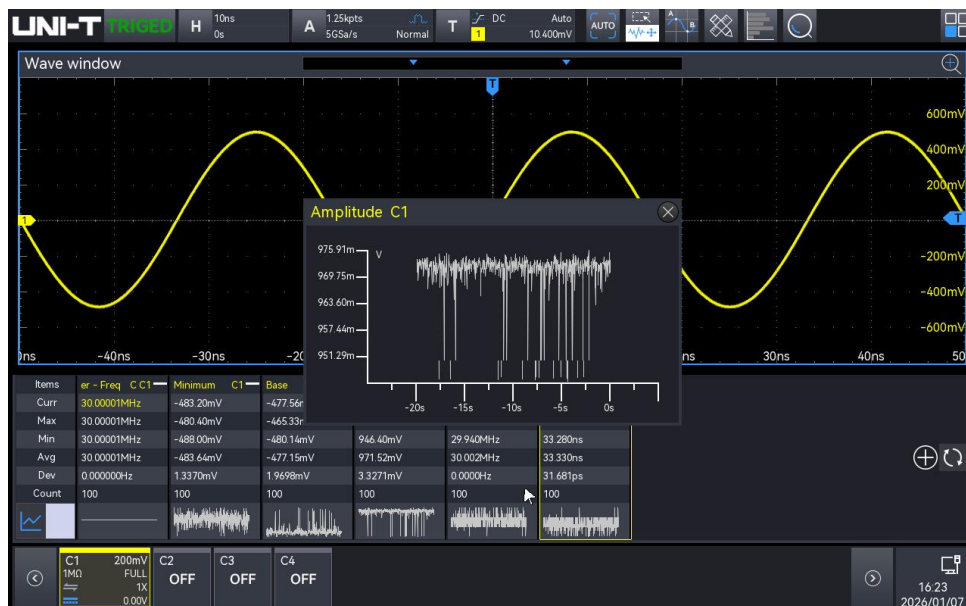

Mathematical Operation

UPO6000LP series provides a system of algorithms for complex waveform operations, allowing you to further process waveforms and display the results directly on the oscilloscope.

- Basic operation: +, -, *, ÷
- Digital filter: High-pass, low-pass, band-pass, and band-limit
- Custom function operation: Analog channel

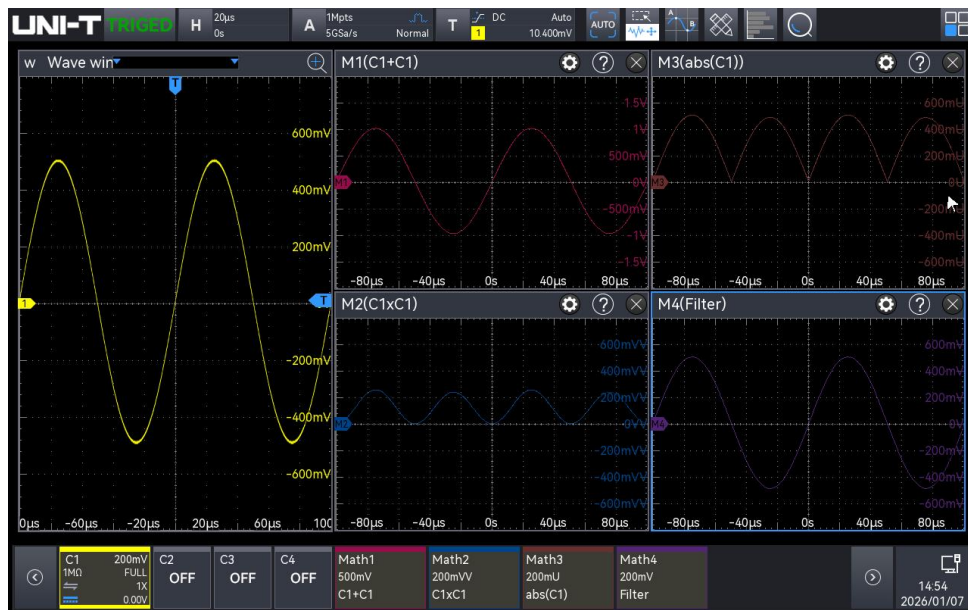

Navigation and Search

The maximum memory depth of the UPO6000LP is upgraded to 500 Mpts/CH. An oscilloscope with high memory depth can capture tens of thousands of waveform cycles in a single acquisition. Locating the desired waveform manually would otherwise take significant time. However, with the oscilloscope's search function, it can automatically search the acquired signals based on user-defined criteria and quickly find the waveform of interest with the help of navigation. With the oscilloscope analysis function, detailed event analysis can be performed, eliminating the time and inconvenience of manual searching. Navigation allows users to easily navigate through search events, time, and markers.

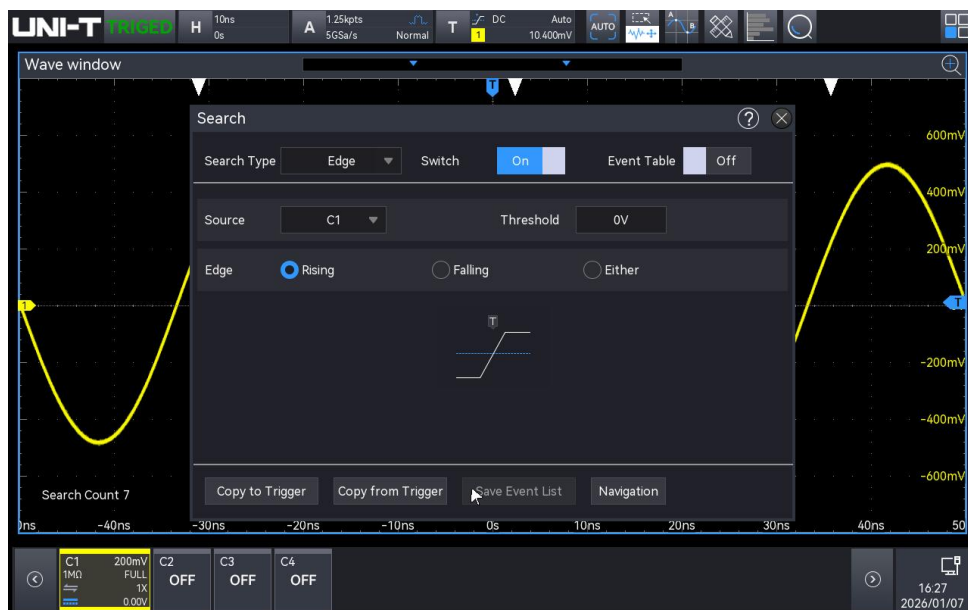

Hardware-accelerated Mask Test

Using the hardware acceleration template for testing allows waveform tests that meet specific standards to be completed in just a few seconds.

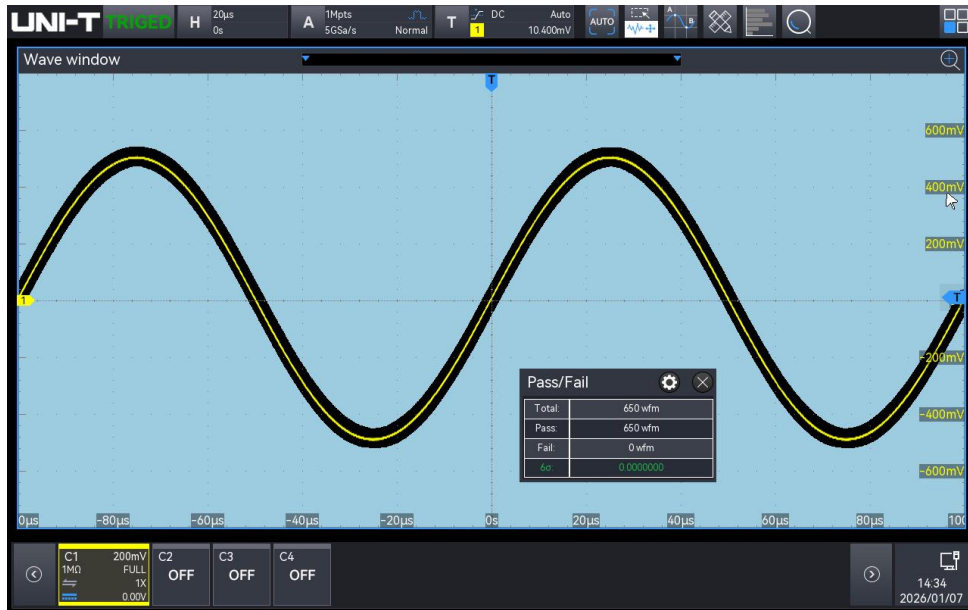

Zone Triggering

Zone triggering serves two primary functions: isolating intermittent anomalies and stabilizing waveform displays. Since a stable trigger is the foundation of a clear display, engineers can use this function to capture and lock complex, variable signals during debugging.

This feature simplifies the workflow by eliminating the learning curve associated with advanced trigger settings. By simply drawing a rectangular "zone" on the screen via touch gestures, users can quickly isolate specific signals of interest. Even when a standard trigger fails to stabilize, zone triggering successfully captures and stabilizes waveforms that meet the defined parameters.

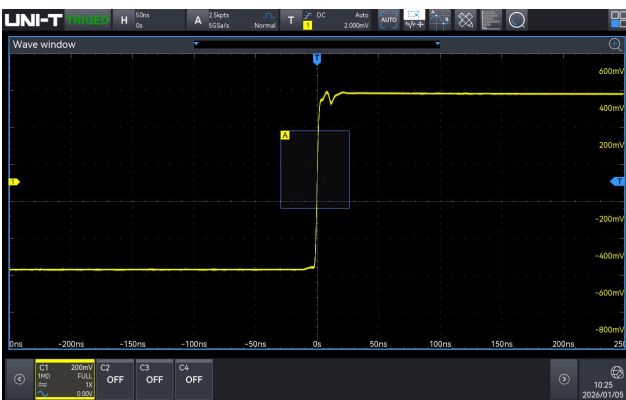

Various Interfaces

The UPO6000LP series provides various interfaces for greater flexibility and convenience.



Multiple Control Methods

Control or secondary development through the instruction set conforming to the SCPI standard.

```
def test_square_character(dst_instr, src_instr, image_list, sheet_list, test_para, show_channel=1234_9800T):
    test_para['AutoTest'] = True
    dst_instr.write("*RST")
    src_instr.write("*RST")
    time.sleep(3)
    dst_instr.write(":ACQ:TYPE AVER")
    dst_instr.write(":ACQ:AVER:COUN 8")
    time.sleep(1)
    data = dst_instr.query("SYSTEM:INFO").strip('\n').strip('\n')
    strArray = data.split(',')
    channelNumbers = 4
    for i in range(channelNumbers):
        srcChannelNumber = i + 1
        dstChannelNumber = i + 1
        channelName = 'CH{0}'.format(dstChannelNumber)
        src_instr.write(":CHANnel{0}:BASE:WAVE SQUARE".format(srcChannelNumber))
        src_instr.write(":CHANnel{0}:OUTPUT, 1".format(srcChannelNumber))
        dst_instr.write(":CHAN{0}:DISP ON".format(dstChannelNumber))
        time.sleep(1)
        dst_instr.write(":CHAN{0}:COUP DC".format(dstChannelNumber))
        dst_instr.write(":WAVEform:SOURce CHAN{0}".format(dstChannelNumber))
        dst_instr.write(":WAVEform:MODE NORMAL")
        dst_instr.write(":WAVEform:FORMat BYTE")
        for amp, vbase in zip(amps, vbases):
            src_instr.write(":CHANnel{0}:BASE:AMPLitude {1}".format(srcChannelNumber, amp))
            time.sleep(0.5)
            dst_instr.write("TRIGger:SOURce CHANnel{0}".format(dstChannelNumber))
            dst_instr.write("CHAN{0}:SCAL {1}.6fV".format(dstChannelNumber, vbase))
            time.sleep(0.1)
        for freq, timeBase, precision in zip(freqs, times, precisions):
            if (freq <= 100):
```

Control via the free UNI-T instrument management software

It can be controlled by installing instrument management software on the PC side through LAN or USB Device.



Remote Control via WebServer

SCPI remote control enables remote viewing and operation

Export waveform files and browse the user manual online

Accessible via PC or mobile phone

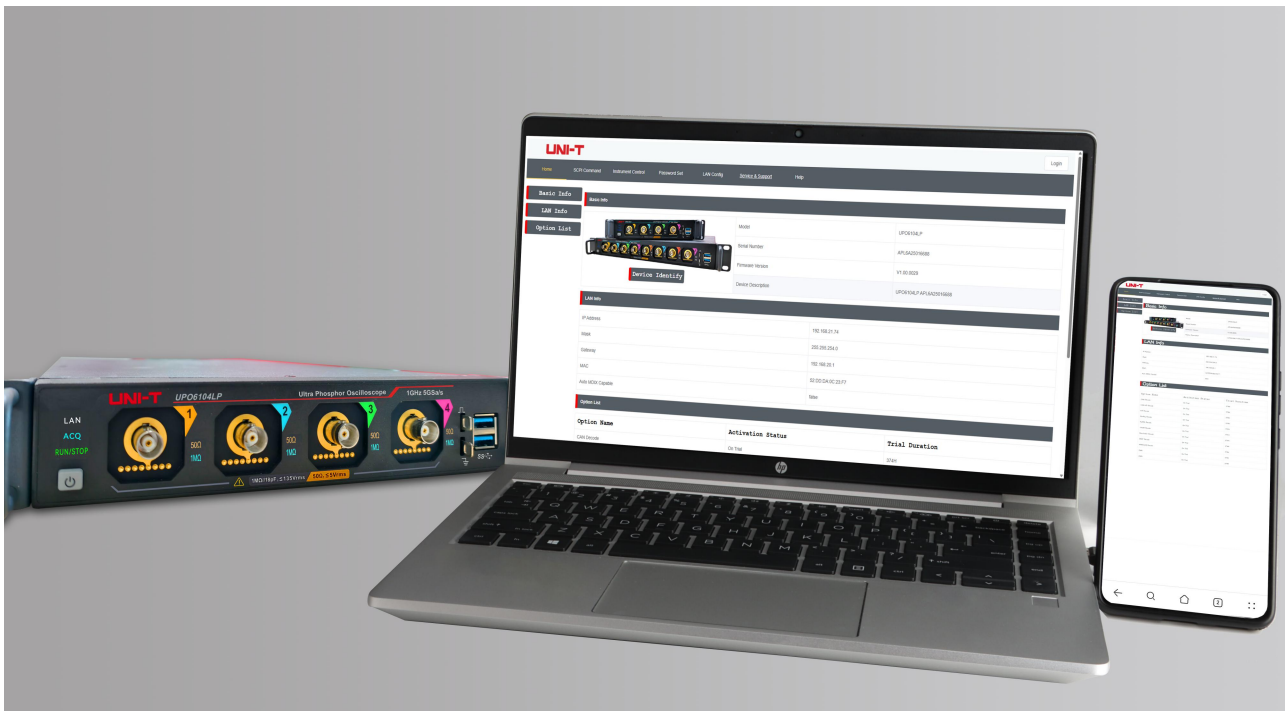

Document Version Revision Notes

Document Version	V1.0
Document Revision Content	The maximum sampling rate for models with a bandwidth of 500 MHz or lower has been increased to 5 GSa/s.Add Timing Analyzer
Four-channel model	Firmware Version: V1.00.0029 Logical Version: V1.00.0011 Hardware Version: V1.02.0000
Eight-channel model	Firmware Version: V1.00.0075 Logical Version: V1.00.0011 Hardware Version: V1.02.0000

Technical Specifications

All specifications are guaranteed, except those marked "Typical (Typ.)".

Unless otherwise stated, all the performance characteristics are suitable for the probe attenuation ratio is set to 10x and UPO6000LP series mixed signal oscilloscope.

To meet these specifications, the oscilloscope should first meet the following conditions.

- The instrument must be operated continuously for at least thirty minutes at the specified operating temperature.
- The self-calibration must be performed when the operating temperature reaches or exceeds 5° C.

Model	UPO6104LP	UPO6054LP	UPO6034LP
	UPO6108LP	UPO6058LP	UPO6038LP
Analog bandwidth (50 Ω, -3 dB)	1 GHz	500 MHz	350 MHz
Analog bandwidth (1 MΩ, -3 dB)	500 MHz	500 MHz	350 MHz
Rise time (Typ.)	≤0.35 ns	≤0.70 ns	≤1.00 ns
Input/Output channel	4-channel, 8-channel		
	1 input EXT channel		
	1 signal generator output channel (optional for 4-channel models only)		
Sampling mode	Real-time		
Acquisition mode	Sampling, peak detection, high resolution, average, ERES		
ERES	Enhanced bit: 1, 1.5, 2, 2.5, 3, 4 (12 to 16-bit)		
Real-time sampling rate	5 GSa/s (Interleaved mode), 2.5 GSa/s (Non-interleaved mode)	5 GSa/s (Interleaved mode), 2.5 GSa/s (Non-interleaved mode)	5 GSa/s (Interleaved mode), 2.5 GSa/s (Non-interleaved mode)
Average	After all channels have completed N sampling times simultaneously, the value of N can be selected from the following options: 2, 4, 8, 16, 32, 64, 128, 256, 512, 1024, 2048, 4096, 8192		
Memory depth	Auto (limited to 5 Mpts), 25 kpts, 250 kpts, 500 kpts, 5 Mpts, 50 Mpts, 100 Mpts, 500 Mpts/CH		
Waveform capture rate	500,000 wfms/s 1,000,000 wfms/s (sequence mode)		
Sequential sampling	Maximum: 400,000 wfms, minimum trigger interval <1,000 ns		

Hardware
real-time
waveform 400,000 wfms
recording and
playback

Vertical System (Analog Channel)

Input coupling	DC, AC, ground
Input impedance	Models with a bandwidth of 1 GHz: (1 MΩ±1%) (16 pF±3 pF); 50 Ω±1% Models with a bandwidth of 500 MHz: (1 MΩ±1%) (17 pF±3 pF); 50 Ω±1%
Probe attenuation ratio	Voltage probe ratio: 0.001X, 0.01X, 0.1X, 1X, 10X, 100X, 1000X, custom Current probe ratio: 5 mV/A, 10 mV/A, 50 mV/A, 100 mV/A, 200 mV/A, 500 mV/A, 1 V/A, custom
Maximum input voltage	1 MΩ: 400 V (DC+ACVpk) 135 V _{RMS} 50 Ω: 5 VRMS Max
Vertical resolution	12-bit
Vertical range	500 μV/div to 10 V/div (1 MΩ) 500 μV/div to 1 V/div (50 Ω)
Offset range	Models with a bandwidth of 1 GHz: 500 μV/div to 100 mV/div: ±2 V (50 Ω and 1 MΩ) 102 mV/div to 1 V/div: ±5 V (50 Ω) 102 mV/div to 1 V/div: ±20 V (1 MΩ) 1.02 V/div to 10 V/div: ±200 V (1 MΩ) Models with a bandwidth of 500 MHz or less: 500 μV/div to 50 mV/div: ±2 V (50 Ω and 1 MΩ) 51 mV/div to 1 V/div: ±5 V (50 Ω) 51 mV/div to 1 V/div: ±25 V (1 MΩ) 1.02 V/div to 10 V/div: ±250 V (1 MΩ) Vertical offset reading: V
Bandwidth limit (Typ.)	50 Ω: 20 MHz, Full, Digital BW 1 MΩ: 20 MHz, Full, Digital BW
Low-frequency response	(AC coupling, -3 dB); ≤5 Hz (on BNC)
DC gain accuracy	<5 mV: ±2% full scale, ≥5 mV: ±1.5% full scale
DC offset accuracy	±(2%+0.1 div+2 mV)
Unit	W, A, V, U, default: V
Channel isolation	DC to Max. bandwidth: >40 dB

Horizontal System (Analog Channel)

	500 ps/div to 1 ks/div
Time base range	Supports fine-tuning (Simultaneously display the sampling rate and memory depth)
Time base accuracy	Initial accuracy: ± 1 ppm; first year aging rate: ± 1 ppm; ten-year aging rate: ± 3.5 ppm
Delay range	Pre-trigger (negative delay): ≥ 1 screen width Post-trigger (positive delay): 1 s to 5 ks
	Y-T (default)
	X-Y (4-channel: CH1-CH4, with two channels combined into pairs)
	X-Y (8-channel: CH1-CH4, with two channels combined into pairs; CH5-CH8, with two channels combined into pairs)
Time base mode	Roll, time base ≥ 100 ms/div; enter or exit Roll mode by adjusting horizontal time base rotary knob
	Scan, time base ≥ 100 ms /div; Roll, Scan mode
Inter-channel delay (Typ.)	<100 ps
Trigger System	
	CH1-CH8: The smaller value of ≤ 10 mV/div, 1 div or 5 mVpp >10 mV/div, 0.5 div
Trigger sensitivity	EXT: 400 mVpp, DC to 10 MHz 800 mVpp, 10 MHz to external trigger bandwidth frequency (250 MHz)
	When noise rejection is enabled, the trigger sensitivity is reduced by half.
External trigger input voltage	1 M Ω : ≤ 42 Vpk 50 Ω : ≤ 5 Vrms
Trigger level	Internal: ± 4 div from the screen center EXT: ± 5 V
Trigger mode	Auto, normal, single
Trigger holdoff	0 ps to 10 s
	DC: Allows all signals to pass
Trigger coupling (Typ.)	AC: Blocks the DC component of the input signal HF reject: Suppresses high-frequency components of signals above 40 kHz LF reject: Suppresses low-frequency components of signals below 40 kHz
Noise reject	Suppress the high-frequency noise of signal, to reduce the error-touched possibility
Trigger jitter	Typical value: <100 psRMS (extremum <200 ps) Normal mode, edge trigger, with the trigger level set around 50% of the EXT

input signal

Zone

Area 2 areas; source: CH1-CH8; feature: intersect, non-intersect

Edge

Edge type Rising edge, falling edge, either

Source CH1-CH8, AC line, EXT

Runt

Pulse width condition Greater than, less than, within range, none

Polarity Positive, negative

Pulse width 3.2 ns to 10 s

Source CH1-CH8

Window

Edge Type Rising edge, falling edge, either

Trigger position Enter, exit, time

Time 3.2 ns to 10 s

Source CH1-CH8

Nth Edge

Edge type Rising edge, falling edge

Idle time 3.2 ns to 10 s

Edge count 1 to 65535

Source CH1-CH8

Delay

Edge type Rising edge, falling edge

Delay condition Greater than, less than, within range, outside range

Delay time 3.2 ns to 10 s

Source CH1-CH8

Timeout

Edge type Rising edge, falling edge, either

Timeout 3.2 ns to 10 s

Source CH1-CH8

Duration

Pattern H, L, X

Trigger condition Greater than, less than, within range

Duration 3.2 ns to 10 s

Source CH1-CH8

Setup & Hold

Edge type	Rising edge, falling edge
Pattern	H, L
Setup time	3.2 ns to 10 s
Hold time	3.2 ns to 10 s
Source	CH1-CH8

Pulse Width

Pulse condition	Positive (Greater than, less than, within range) Negative (Greater than, less than, within range)
Pulse width	0.8 ns to 4 s
Source	CH1-CH8, AC line, EXT

Ramp

Condition	Positive (Greater than, less than, within range) Negative (Greater than, less than, within range)
Time setting	3.2 ns to 1 s
Source	CH1-CH8

Video

	Triggers on all lines, specified field, odd field, or even field that comply with video standards.
Signal standards	Video standards: PAL, NTSC, SECAM, 525p/60, 625p/50, 720p/24, 720p/25, 720p/30, 720p/50, 720p/60, 1080i/25, 1080i/30, 1080p/24, 1080p/25, 1080p/30, 1080pfs/24
Source	CH1-CH8

Pattern

Pattern	H, L, X, rising edge, falling edge
Source	CH1-CH8

RS232/UART

Trigger condition	Start, FrameErr, CheckErrr, Data
Baud rate	2400 bps, 4800 bps, 9600 bps, 19200 bps, 38400 bps, 57600 bps, 115200 bps, custom
Data bit	5 bits, 6 bits, 7 bits, 8 bits
Source	CH1-CH8

I²C

Trigger condition	Start, Restart, Stop, Loss, Address, Data, Address & Data
Address bit	7 bits, 10 bits
Address range	0 to 7F, 0 to 3FF
Byte length	1 to 5

Data qualifier	=, >, <
Source	CH1-CH8
SPI	
Trigger condition	CS, idle time
Timeout	100 ns to 1 s
Data bit	4 to 32 bits
Pattern	H, L, X
Clock edge	Rising edge, falling edge
Source	CH1-CH8
CAN	
Signal type	CAN_H, CAN_L
Trigger condition	Start, Data Frame, Remote Frame, Error Frame, Over-Load, Identifier, Data, ID&Data, End of Frame, Lost ACK, Stuff Error, CRC Error, All Errors
Data rate	10 kbps, 19.2 kbps, 20 kbps, 33.3 kbps, 38.4 kbps, 50 kbps, 57.6 kbps, 62.5 kbps, 83.3 kbps, 100 kbps, 115.2 kbps, 125 kbps, 230.4 kbps, 250 kbps, 490.8 kbps, 500 kbps, 800 kbps, 921.6 kbps, 1 Mbps, 2 Mbps, 3 Mbps, 4 Mbps, 5 Mbps, custom
Source	CH1-CH8
CAN-FD	
Signal type	CAN_H, CAN_L
Trigger condition	Start, Data Frame, Remote Frame, Error Frame, Over-Load, Identifier, Data, ID&Data, End of Frame, Lost ACK, Stuff Error, CRC Error, All Errors
Data rate	10 kbps, 19.2 kbps, 20 kbps, 33.3 kbps, 38.4 kbps, 50 kbps, 57.6 kbps, 62.5 kbps, 83.3 kbps, 100 kbps, 115.2 kbps, 125 kbps, 230.4 kbps, 250 kbps, 490.8 kbps, 500 kbps, 800 kbps, 921.6 kbps, 1 Mbps, 2 Mbps, 3 Mbps, 4 Mbps, 5 Mbps, custom
FD data rate	250 kbps, 500 kbps, 800 kbps, 1 Mbps, 1.5 Mbps, 2 Mbps, 4 Mbps, 6 Mbps, 8 Mbps, custom
Source	CH1-CH8
LIN	
Trigger condition	Sync, Identifier, Data, ID & Data, Wake Frame, Sleep Frame, Error
Version	V1, V2, either
Baud rate	1.2 kbps, 2.4 kbps, 4.8 kbps, 9.6 kbps, 10.417 kbps, 19.2 kbps, 20 kbps, custom
Data length	1 to 8
Source	CH1-CH8
FlexRay	

Trigger condition	Start, Indicators, Identifier, Cycle, Heade, Data, ID & Data, End of Frame, Error
Polarity	BM, BDiff, BP
Baud rate	2.5 Mbps, 5 Mbps, 10 Mbps, custom
Source	CH1-CH8
Audio	
Trigger condition	Word, Left, Right, Any
Format	Standard, Left Aligned, Right Aligned, TDM
Source	CH1-CH8
MIL-STD-1553B	
Trigger condition	Sync, Command, Status, Data, Error
Polarity	Positive, negative
Response time	2 μ s to 100 μ s
Source	CH1-CH8
SENT	
Trigger condition	Fast mode: Sync, Status, Data, CRC, Status+Data, S&D +CRC, Fast CRC Error, Continuous Pulse Error Slow mode: Sync, Short ID, Short Data, Short CRC, Short ID & Data, Enhanced ID, Enhanced Data, Enhanced CRC, Enhanced ID & Data, Slow CH CRC error
Source	CH1-CH8
Manchester	
Trigger condition	Start, Header, Data field, Trailer, Error
Baud rate	500 bps to 10 Mbps
Source	CH1-CH8
ARINC 429	
Trigger condition	Start, Stop, Label, SDI, Data, SSM, Label+ Bit Count, Parity Error, Bit Error, Gap Error, All Errors
Source	CH1-CH8
Decoding	
Number	4
Decoding type	Standard: RS232/UART, I ² C, SPI Option: CAN, CAN-FD, LIN, FlexRay, Audio, MIL-5TD-1553B, SENT, ARINC 429, Manchester
Parallel	Up to 4-bit parallel bus decoding
Source	CH1-CH4 or CH5-CH8
Search and Navigation	

Type	Edge, Pulse Width, Slop, Runt, Window, Delay, Timeout, Duration, Setup & Hold, Nth Edge, Pattern
Source	Any one of the analog channels
Copy	Copy from trigger to copy trigger
Result display	Event list or navigation. Jump to a specific event by selecting an entry in the event list.
Navigation	Event, time, marker
Waveform Recording	
Source	All enabled analog channels
Analysis	Supports frame-by-frame or continuous playback. It can perform operations and measurements on the waveform being played.
Pass/Fail	
Source	Any one of the analog channels
Measurement	Pass/fail events can trigger immediate stop, beeper, and screenshot
Measurement	
Cursor	Voltage difference between cursors (ΔY)
	Time difference between cursors (ΔX)
	Reciprocal of ΔX (Hz) ($1/\Delta X$)
	Voltage and time of waveform point
Display the cursor in the automatic measurement	
Automatic measurements	56 types of parameters: Maximum, Minimum, Top, Base, Amplitude, Middle, Peak-Peak, Amplitude, Average, Average-Cycles, RMS, RMS-Cycles, AC RMS, AC RMS-Cycles, Area, Area-Cycles, +Area, -Area, +Area-Cycles, -Area-Cycles, +Overshoot, -Overshoot, +Preshoot, -Preshoot, Frequency, Period, Rise time, Fall time, +Width, -Width, +Duty, -Duty, Rise Delay, Fall Delay, Phase, Ratio, Period Ratio, Setup Time, Hold Time, Setup & Hold Ratio, FRFR, FRFF, FFFR, FFFF, FRLF, FRLR, FFLR, FFLF, +Pulse Count, -Pulse Count, Rise Edge Count, Fall Edge Count, Burst Width, Burst Interval, Burst Period, Burst Period Count
Measurement mode	Common measurement and accuracy measurement (Full memory hardware measurements)
Measurement type	Simultaneously display 27 kinds of parameter measurement
Measurement range	Main time base, zoom time base, cursor area
Measurement and statistics	Average, maximum, minimum, standard deviation, measurement count, line chart, histogram
XY measurement	Time, Cartesian, Polar, Product, Ratio

Measurement source	C1-C8, M1-M8
Analysis	Frequency Counter, DVM, Pass/Fail, Waveform recording, Bode plot, Power Analysis
Power Analysis (Option)	
Analysis type	Power quality, Harmonics, Surge current, Rds(on), Switching loss, Conversion rate, Safe operating area, Modulation analysis, Ripple analysis, Startup/shutdown time, Transient response, Power efficiency, Timing analysis
Three-Phase Power Analysis (Option)	
Analysis type	Power quality, Harmonics, Ripple analysis, Power efficiency, DQ0
Histogram	
Source	C1-C8
Type	Horizontal, vertical
Measurement	Sampling point, peak, maximum, minimum, peak-to-peak, average, average, median, mode, Bin width, standard deviation
Time base mode	Supports all modes, except Roll mode
Math	
Waveform calculation	A+B, A-B, A×B, A÷B, Advanced, Filter
Digital filter	Low pass, high pass, band pass, band stop
Advanced operation	0, 1, 2, 3, 4, 5, 6, 7, 8, 9, (, +, -, *, /, ^, >, <, &&, , ==, !=, =)
Function	Sin, Cos, Sinc, Tan, Sqrt, Exp, Lg, ln, Floor, ABS, Acos, Asin, Atan, Sinh, Tanh, Ceil, Cosh, Fabs, intg, diff, sign
FFT	
Channel number	4
FFT window type	Hanning, Hamming, Rectangle, Blackman, Flat Top
FFT count	Up to 5 Mpts
FFT vertical scale	Vrms, dBV, dBm(50Ω)
FFT	Waterfall curve: On, off
	Spectrum range: Start frequency, Stop frequency, Center frequency, Span
	Four traces: Normal, Average, Maximum Hold, Minimum Hold
	Marker: Marker type, Marker Points, Marker list
Memory	
Setting	Instrument setting status (*.set)
Waveform	Waveform data (*.dat), comma separate value (*.csv), arbitrary waveform (*.bsv)

Image	Image format (*.bmp), (*.png), (*.jpg)
Report	Decoding event list format (*.csv), (*.html), (*.pdf)
Gen (Optional for 4-channel models only)	
Channel number	1
Sampling rate	312.5 MSa/s
Vertical resolution	16-bit
Maximum frequency	50 MHz
Standard waveform	Sine, square, pulse, ramp, noise, DC, arbitrary waves
Built-in waveform	Sinc, Exp.Rise, Exp.Fall, ECG, Gauss, Lorentz, and Haversine, etc (200 types)
Sine	Frequency range: 1 μ Hz to 50 MHz
	Flatness: ± 0.5 dB (relative to 1 kHz)
	Harmonic distortion: -40 dBc
	Spurious (non-harmonics): -40 dBc
	Total harmonic distortion: 1% (DC to 20 kHz, 1 Vpp)
Square/Pulse	SNR: 40 dB
	Frequency range: Square: 1 μ Hz to 15 MHz; Pulse: 1 μ Hz to 15 MHz
	Rise/Fall time: <20 ns (Typical value 1 kHz, 1 Vpp, 50 Ω)
	Overshoot: Typical value 2% (1 kHz, 1 Vpp, 50 Ω)
	Duty ratio: Square: 1% to 99%, adjustable; Pulse: 1% to 99%, adjustable
	Duty ratio resolution: 1% or 10 ns (whichever is greater)
Ramp	Minimum pulse width: 20 ns
	Pulse width resolution: 10 ns
	Jitter: 2 ns
Noise	Frequency range: 1 μ Hz to 400 kHz
	Linearity: 1%
	Symmetry: 0.1% to 99.9%
Arbitrary	Bandwidth: 50 MHz (Typ.)
	Frequency range: 1 μ Hz to 5MHz
	Waveform length: 16 k
Frequency	Built-in arbitrary waveform: 200 types
	Accuracy: Initial accuracy: ± 1 ppm; first year aging rate: ± 1 ppm; ten-year aging rate: ± 3.5 ppm

	Resolution: 1 μ Hz
Amplitude	Output range: 20 mVpp to 6 Vpp (High resistance); 10 mVpp to 3 Vpp (50 Ω)
	Resolution: 1 mV
	Accuracy (Typical value: 1 kHz sine, 0 V offset): \pm (5% of the setting value+2 mVpp)
DC offset	Range: \pm 3 V (High resistance); \pm 1.5 V (50 Ω)
	Resolution: 1 mV
	Accuracy: \pm (5% of the setting value+2 mV)

AM

Carrier waveform	Sine, square, ramp, arbitrary
Source	Internal
Modulation waveform	Sine, square, rise ramp, fall ramp, noise, arbitrary
Modulation frequency	2 mHz to 50 kHz
Modulation depth	0% to 120%

FM

Carrier waveform	Sine, square, ramp, arbitrary
Source	Internal
Modulation waveform	Sine, square, rise ramp, fall ramp, noise, arbitrary
Modulation frequency	2 mHz to 50 kHz
Frequency offset	12.5 MHz (Maximum)

ASK

Carrier waveform	Sine, square, ramp, arbitrary
Modulation waveform	50% duty ratio square wave
Modulation frequency	2 mHz to 50 kHz

FSK

Carrier waveform	Sine, square, ramp, arbitrary
Modulation waveform	50% duty ratio square wave
Modulation frequency	2 mHz to 50 kHz

Hopping frequency	Frequency within the carrier waveform range
Sweep	
Mode	Linear, logarithm
Sweep time	1 ms to 500 s
Start/Stop frequency	Frequency within the waveform range
TimingAnalysis (Option)	
Type	I2C, SPI, CAN, I2S
Display	
Persistence	Auto, 50 ms, 100 ms, 200 ms, 500 ms, 1 s, 5 s, 10 s, 20 s, infinite, close
Display type	Point, Vector
Real-time clock	Time and data (user-defined)
Waveform brightness	1% to 100% (default 50%)
Grid brightness	0% to 100% (default 50%)
Backlight brightness	1% to 100% (default 50%)
Window transparent	0% to 100% (default 50%)
Waveform scale	Moveable, fixed
Staff	Display, hide
Temperature color	On, Off
Bode Plot (Optional for 4-channel models only)	
Mode	Bode plot, PSRR (power supply rejection ratio)
Start frequency	50 Hz to 50 MHz
Stop frequency	60 Hz to 50 MHz
Count	1 to 1000
Output amplitude	High resistance: 20 mVpp to 6 Vpp 50 Ω : 10 mVpp to 3 Vpp
DVM (Technical specifications are typical values)	
Source	Any one of the analog channels
Function	DC, AC+DC RMS, AC RMS
Resolution	4-digit
Limit alarm	Sound an alarm when the voltage value is within or outside of the limit range
Measurement	Vertical area

 range

 Measurement window 100 ms

High-precision Frequency Counter

 Source Any one of the analog channels or the trigger channel

 Measurement Frequency, period, totalizer

 Counter Maximum effective digit: 7-digit, refresh time and effective digit are adjustable

 Maximum measuring frequency Maximum bandwidth of analog channel

 Time reference Internal reference: Initial accuracy: ± 1 ppm; first year aging rate: ± 1 ppm; ten-year aging rate: ± 3.5 ppm

Interface

 USB-Host 3.0 2 on the front panel, 2 on the rear panel

 USB-Device 3.0 1 on the rear panel

 LAN LAN (VXI11), 10/100/1000 Base-T, RJ-45

 AUX Out Trig Out, Pass/Fail, DVM

 Gen Out 1 on the rear panel (optional for 4-channel models only)

 10 MHz reference input 50 Ω , amplitude 400 mVpp to 4.5 Vpp (-3.979 dBm, 17.044 dBm), frequency 10 MHz ± 10 ppm

 10 MHz reference output 50 Ω , 1.65 Vpp square wave

 HDMI¹ 1 port for external display or projector

General Specification

Probe Compensator

 Output voltage Approx. 3Vp-p

 Frequency 1 kHz (default), 3V_REF

Power Supply

 Power voltage 100 V to 240 VAC (fluctuation: $\pm 10\%$), 50 Hz/60 Hz

 Power 140 W (200 W) Max.

 Fuse 5A, T-class, 250 V

Environmental Condition

 Temperature Operating: 0°C to +50°C

 range Non-operating: -40°C to +70°C

 Cooling Forced cooling by fan

 Humidity range +10°C and below: any relative humidity

	+10°C to +30°C, 5% to 95% RH +30°C to +40°C, 5% to 75% RH +40°C to +50°C, 5% to 45% RH
Altitude	Operating: below 4,600 meters; non-operating: below 15, 000 meters
Pollution degree	2
Operating environment	Indoor use

Mechanical Specifications

Dimension (W×H×D)	4-channel: 214mm×43mm×380mm 8-channel: 339mm×43mm×450mm
Weight	4-channel: 2.5kg 8-channel: 5.5kg

Calibration Interval

Calibration interval	1
----------------------	---

Safety Regulations

Compliance with EMC directive (2014/30/EU), compliance with or superior to IEC 61326-1:2021/EN61326-1:2021, IEC 61326-2-1:2021/EN61326-2-1:2021

Electromagnetic compatibility	Conducted disturbance	CISPR 11/EN 55011	CLASS B group 1, 150 kHz-30 MHz
	Radiation disturbance	CISPR 11/EN 55011	CLASS B group 1, 30 MHz-1 GHz
	Electrostatic discharge (ESD)	IEC 61000-4-2/EN 61000-4-2	±4.0 kV (contact), ±8.0 kV (air)
	Radio frequency electromagnetic field immunity	IEC 61000-4-3/EN 61000-4-3	3 V/m (80 MHz to 1 GHz) 1 V/m (1.4 GHz to 6 GHz)
	Electrical fast transient (EFT)	IEC 61000-4-4/EN 61000-4-4	±1 kV (AC input)
	Surge	IEC 61000-4-5/EN 61000-4-5	±0.5 kV (live to zero) ±1 kV (live/zero to ground)
	Radio continuous sensitivity	IEC 61000-4-6/EN 61000-4-6	3V, 0.15-80 MHz
	Voltage dip and short-term interruption	IEC 61000-4-11/EN 61000-4-11	Voltage dip: 0% UT during 0.5 cycle 0% UT during 1 cycle 70% UT during 25/30

cycles
Short-term interruption:
0% UT during 250/300
cycles

Safety specification	EN 61010-1:2010+A1:2019
	EN IEC61010-2-030:2021+A11:2021
	BS EN61010-1:2010+A1:2019
	BS EN IEC61010-2-030:2021+A11:2021
	UL61010-1:2012 Ed.3+ R:19 Jul2019
	UL61010-2-030:2018 Ed.2
	CSA C22.2#61010-1:2012 Ed.3+U1:U2:A1
CSA C22.2#61010-2-030:2018 Ed.2	

Note

1: Supports standard HDMI only; adapters are not supported.

Order Information and Warranty

Order Information







	Description	Order No.
Model	UPO6104LP (1 GHz, 4 analog channels, Gen)	UPO6104LP
	UPO6054LP (500 MHz, 4 analog channels, Gen)	UPO6054LP
	UPO6034LP (350 MHz, 4 analog channels, Gen)	UPO6034LP
	UPO6108LP (1 GHz, 8 analog channels)	UPO6108LP
	UPO6058LP (500 MHz, 8 analog channels)	UPO6058LP
	UPO6038LP (350 MHz, 8 analog channels)	UPO6038LP
Standard accessories	National standard cable x 1	
	USB 3.0 cable x 1	UT-D30
	BNC-BNC x 1 (optional for 4-channel models only)	UT-L45
Optional accessories	Passive probe (500 MHz/350 MHz) (4/8)	UT-P07A/UT-08A
	Isolation transformer	UT-ISOT
	High-voltage probe	UT-V23/UT-P21/UT-P20
	High-voltage differential probe	UT-P30/UT-P31/UT-P32/ UT-P33/UT-P35/UT-P36
	Active probe	UT-PA2000, UT-PA1000, UT-PD2500, UT-PD15000
	Current probe	UT-P40/UT-P41/UT-P42/ UT-P43/UT-P44/UT-P4030D /UT-P4150/UT-P4500/P4100 A/P4100B
Option software	Deskew fixture	UT-DF01
	All Serial Bus Trigger and Decode Options (including EMBD, AUTO, Audio, MIL-STD, ARINC, Manchester)	UPO6000LP-BND
	Automotive serial bus triggering and decoding option (CAN, CAN-FD, LIN, FlexRay, Sent)	UPO6000LP-AUTO
	CAN: Automotive serial bus triggering and decoding	UPO6000LP-CAN
	CAN-FD: Automotive serial bus triggering and decoding	UPO6000LP-CAN-FD
	LIN: Automotive serial bus triggering and decoding	UPO6000LP-LIN

FlexRay: Automotive serial bus triggering and decoding	UPO6000LP-FLEX
SENT: Automotive serial bus triggering and decoding	UPO6000LP-SENT
Audio: Audio serial bus triggering and decoding option	UPO6000LP-AUDIO
MIL-STD-1553: Aerospace serial bus triggering and decoding	UPO6000LP-MIL1553
ARINC429: Aerospace serial bus triggering and decoding	UPO6000LP-ARINC429
MANCHESTER: Wireless communication serial bus triggering and decoding	UPO6000LP-MANCH
Single-Channel 50 MHz Arbitrary Waveform Generator Option(Supported only on 4-channel models,including Gen and Bode Plot)	UPO6000LP-Gen
Power Analysis Option (including advanced power analysis and three-phase power analysis (Supported only on 8-channel models))	UPO6000LP-PWR
Time sequence analyzer (Including I2C, SPI, CAN, RS-232/422/485/UART)	UPO6000LP-TIMING

Note: Please order all hosts, accessories and options from your local UNI-T distributor.

Oscilloscope Probe and Accessories

Passive Probe

Model	Type	
UT-P01	High-impedance probe	1X: DC to 8 MHz 10X: DC to 25MHz Oscilloscope compatibility: All UNI-T series
		
UT-P03	High-impedance probe	1X: DC to 8 MHz 10X: DC to 60 MHz Oscilloscope compatibility: All UNI-T series
		
UT-P04	High-impedance probe	1X: DC to 8 MHz 10X: DC to 100 MHz Oscilloscope compatibility: All UNI-T series
		
UT-P05	High-impedance probe	1X: DC to 8 MHz 10X: DC to 200 MHz Oscilloscope compatibility: All UNI-T series
		
UT-P06	High-impedance probe	1X: DC to 8 MHz 10X: DC to 300 MHz Oscilloscope compatibility: All UNI-T series
		
UT-P07A	High-impedance probe	10X: DC to 500 MHz Input resistance: 10 MΩ Maximum operating voltage: <600V pk Oscilloscope compatibility: All UNI-T series
		

UT-P08A



High-impedance probe

10X: DC to 350 MHz
 Input resistance: 10 M Ω
 Maximum operating voltage: <600V pk
 Oscilloscope compatibility: All UNI-T series

UT-P20



High-impedance probe

DC to 100 MHz
 Probe attenuation ratio: 100:1
 Maximum operating voltage: 1500 Vrms
 Oscilloscope compatibility: All UNI-T series

UT-V23



High-voltage probe

DC to 100 MHz
 Probe attenuation ratio: 100:1
 Input resistance: 100 M Ω ±2%
 Maximum operating voltage: 2000 Vpp
 Oscilloscope compatibility: All UNI-T series

UT-P21



High-voltage probe

DC to 50 MHz
 Probe attenuation ratio: 1000:1
 Maximum operating voltage: DC 15 kVrms, AC 10 kV (Sine wave)
 Oscilloscope compatibility: All UNI-T series

Current Probe







Model	Type
UT-P40	Current probe
UT-P41	



DC to 100 kHz
 Range: 50 mV/A, 5 mV/A
 Current range: 0.4 A to 60 A
 Maximum operating voltage: 600 Vrms
 Oscilloscope compatibility: All UNI-T series



DC to 100 kHz
 Range: 100 mV/A, 10 mV/A
 Current range: 0.4 A to 100 A
 Maximum operating voltage: 600 Vrms
 Oscilloscope compatibility: All UNI-T series

<p>UT-P42</p> 	<p>Current probe</p>	<p>DC to 150 kHz Range: 100 mV/A, 10 mV/A Current range: 0.4 A to 200 A Maximum operating voltage: 600 Vrms Oscilloscope compatibility: All UNI-T series</p>
<p>UT-P43</p> 	<p>Current probe</p>	<p>DC to 25 MHz Range: 100 mV/A Maximum measuring current: 20 A Rise time: 14 ns Oscilloscope compatibility: All UNI-T series</p>
<p>UT-P44</p> 	<p>Current probe</p>	<p>DC to 50 MHz Range: 50 mV/A Maximum measuring current: 40 A Rise time: 7 ns Oscilloscope compatibility: All UNI-T series</p>
<p>UT-P4030D</p> 	<p>High-frequency current Probe</p>	<p>Bandwidth: DC to 100 MHz Rise time: ≤ 3.5 ns Range: 30 A/5 A Maximum measuring current: 30 A Insulated wire voltage: 300V CAT I Oscilloscope compatibility: All UNI-T series</p>
<p>UT-P4150</p> 	<p>High-frequency current Probe</p>	<p>Bandwidth: DC to 12 MHz Rise time: ≤ 29 ns Range: 150 A/30 A Maximum measuring current: 150 A Insulated wire voltage: 600V CATII 300V CATIII Oscilloscope compatibility: All UNI-T series</p>
<p>UT-P4500</p> 	<p>High-frequency current Probe</p>	<p>Bandwidth: DC to 5 MHz Rise time: ≤ 70 ns Range: 500 A/75 A Maximum measuring current: 500A Insulated wire voltage: 600V CATII 300V CATIII Oscilloscope compatibility: All UNI-T series</p>

UT-P4100A



Low-frequency AC/DC current Probe

Bandwidth: DC to 600 kHz

Rise time: ≤ 583 ns

Maximum measuring current: 100 A

Range: 100 A/10 A

Range sensitivity: 0.1 V/A, 0.01 V/A

Common-mode voltage RMS: CATI 600V

CATII 600V CATIII 300V

Oscilloscope compatibility: All UNI-T series

UT-P4100B



Low-frequency AC/DC current Probe

Bandwidth: DC to 2 MHz

Rise time: ≤ 175 ns

Maximum measuring current: 100 A

Range: 100 A/10 A

Range sensitivity: 0.1 V/A, 0.01 V/A

Common-mode voltage RMS: CATI 600V

CATII 600V CATIII 300V

Oscilloscope compatibility: All UNI-T series

Active Probe

Model	Type
UT-PA2000	Active single-ended probe
UT-PA1000	Active single-ended probe
UT-PD2500	Active differential probe



10X: DC to 2 GHz

Input capacitance: ≤ 3.5 pF

Dynamic range: ± 4 V (DC or peak AC)



10X: DC to 1 GHz

Input capacitance: ≤ 3.5 pF

Dynamic range: ± 4 V (DC or peak AC)



10X: DC to 2.5 GHz

Input capacitance: ≤ 1 pF

Dynamic range: ± 4 V (DC or peak AC)

UT-PD1500



Active
differential
probe

10X: DC to 1.5 GHz
Input capacitance: ≤ 1 pF
Dynamic range: ± 4 V (DC or peak AC)

UT-P30



High-voltage
differential
probe

DC to 100 MHz
Probe attenuation ratio: 100:1, 10:1
Input differential-mode voltage: ± 800 Vpp
Oscilloscope compatibility: All UNI-T series

UT-P31



High-voltage
differential
probe

DC to 100 MHz
Probe attenuation ratio: 1000:1, 100:1
Input differential-mode voltage: ± 1.5 kVpp
Oscilloscope compatibility: All UNI-T series

UT-P32



High-voltage
differential
probe

DC to 50 MHz
Probe attenuation ratio: 1000:1, 100:1
Input differential-mode voltage: ± 3 kVpp
Oscilloscope compatibility: All UNI-T series

UT-P33



High-voltage
differential
probe

DC to 120 MHz
Probe attenuation ratio: 1000:1, 100:1
Input differential-mode voltage: ± 14 kVpp
Oscilloscope compatibility: All UNI-T series

UT-P35



High-voltage
differential
probe

DC to 50 MHz
 Probe attenuation ratio: 500:1, 50:1
 Rise time: 7 ns
 Accuracy: 2%
 Input differential-mode voltage:
 1/50:130 (DC+peakAC)
 1/500:1300 (DC+peakAC)
 Input common-mode voltage:
 100 Vrms, CATI
 600 Vrms, CATII
 Oscilloscope compatibility: All UNI-T series

UT-P36



High-voltage
differential
probe

DC to 50 MHz
 Probe attenuation ratio: 2000:1, 200:1
 Rise time: 3.5 ns
 Accuracy: 2%
 Input differential-mode voltage:
 1/200:560 (DC+peakAC)
 1/2000:5600 (DC+peakAC)
 Input common-mode voltage:
 2800 Vrms, CATI
 1400 Vrms, CATII
 Oscilloscope compatibility: All UNI-T series

Options Ordering and Installation

1. **Purchase options:** Based on your requirements, please purchase the specified function options from UNI-T Sales Personnel and provide the serial number of the instrument that needs the option installed.
2. **Receive certificate:** You will receive the license certificate based on the address provided in the order.
3. **Register and obtain license:** Visit the UNI-T official website license activation session for registration. Use the license key and instrument serial number provided in the certificate to obtain the option license code and license file.
4. **Install the option:** Download the option license file to the root directory of a USB storage device, and connect the USB storage device to the instrument. Once the USB storage device is recognized, the Option Install menu will be activated. Press this menu key to begin installing the option.

Limited Warranty and Liability

UNI-T guarantees that the Instrument product is free from any defect in material and workmanship within three years from the purchase date. This warranty does not apply to damages caused by accident, negligence, misuse, modification, contamination, or improper handling. If you need a warranty service within the warranty period, please contact your seller directly. UNI-T will not be responsible for any special, indirect, incidental, or subsequent damage or loss caused by using this device. For the probes and accessories, the warranty period is one year. Visit instrument.uni-trend.com for full warranty information.



Learn more at: www.uni-trend.com



Register your product to confirm your ownership. You will also get product notifications, update alerts, exclusive offers and all the latest information you need to know.

UNI-T is the licensed trademark of UNI-TREND TECHNOLOGY (CHINA) CO., Ltd.

UNI-T products are protected under patent laws in China and internationally, covering both granted and pending patents. Licensed software products are the properties of UNI-Trend and its subsidiaries or suppliers, all rights reserved. This manual contains information that replaces all earlier published versions. The product information in this document subject to update without notice. For more information on UNI-T Test & Measure Instrument products, applications, or service, please contact UNI-T instrument for support, the support center is available on www.uni-trend.com ->instruments.uni-trend.com

<https://instruments.uni-trend.com/ContactForm/>

Headquarter

UNI-TREND TECHNOLOGY (CHINA)
CO., Ltd.
Address: No.6, Industrial North 1st
Road, Songshan Lake Park, Dongguan
City, Guangdong Province, China
Tel: (86-769) 8572 3888

Europe

UNI-TREND TECHNOLOGY EU GmbH
Address: Steinerne Furt 62, 86167
Augsburg, Germany
Tel: +49 (0)821 8879980

North America

UNI-TREND TECHNOLOGY US INC.
Address: 2692 Gravel Drive,
Building 5, Fort Worth, Texas 76118
Tel: +1-888-668-8648